

A guide to cycle parking

Shrewsbury is one of only 18 cycling towns in England. The Cycle Shrewsbury campaign can provide resources and information to make it easier for people to cycle to work or on their business trips round town.

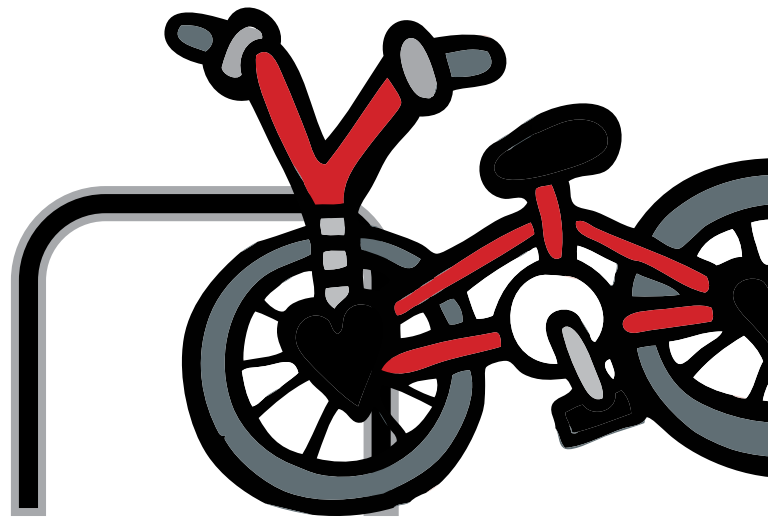

1. Location

The location of cycle parking is the most important factor. Parking needs to be as close to the entrance of a building as possible to offer a significant advantage over car parking.

People are often concerned about the safety of their bikes when they are parked for a considerable amount of time and to combat this, cycle parking must always be in a visible location. If cycle parking is overlooked by windows or in a position where people are constantly moving around, it will be secure. By putting cycle parking 'out of the way', you may be allowing potential thieves to work without hindrance.

2. Design and installation

The choice of stand is very important for several reasons. Even if a cyclist only leaves their bike for a short time, they will want to know it is secure. The stand must be sturdy yet easy to use with a variety of locks, including 'D' type locks. Stands must also make it easy for both bicycle frames and wheels to be secured to.



THE MAIN POINTS TO CONSIDER WHEN PLANNING CYCLE PARKING:

- Location
- Design and installation
- How much parking is needed
- Cost/funding

The Cycle Shrewsbury team recommend the use of 'Sheffield' type stands (made from a single tube with two right angled bends). The design is easy to use, strong and safe.

The design can be further improved with the inclusion of a lower cross bar which makes locking children's bikes or open-frame styles easier and more secure. There are other designs of stands available that may be more in keeping with your property and can be equally effective as the standard 'Sheffield' stands. Parking stands can come supplied with a variety of finishes including paint, scratch resistant finishes or they can be made from stainless steel.'

Staff cycle parking should be under cover, either inside or outside the building. Outdoor shelters can be open or can be lockable compounds opened by key, combination lock or swipe card system.

Visitor cycle parking should be provided close to the main entrance. It does not need to be under cover.

Cycle parking stand 'footprint' (plan view)

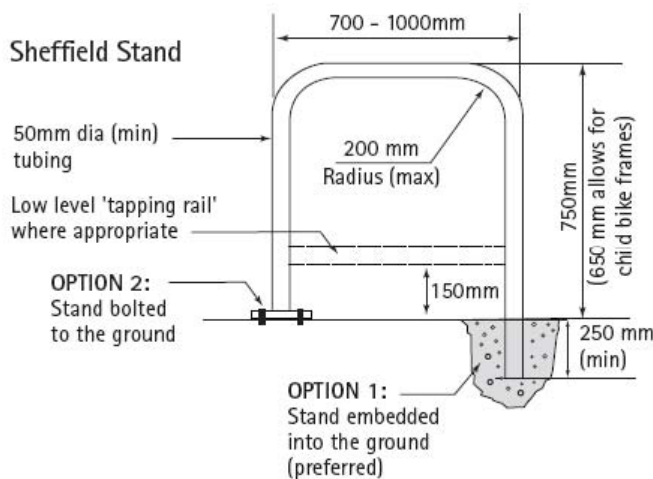
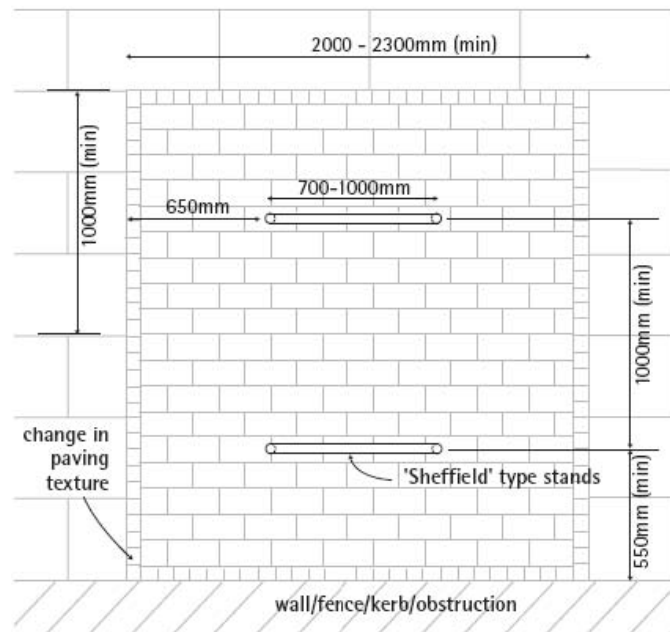

3. How much parking is needed?

Before installing any cycle parking, the demand must be determined. Cycle Shrewsbury can provide a survey template to assess existing attitudes to cycling and demand for facilities. Demand can be expected to rise once facilities improve so the cycle parking should allow for this. Depending on the size of your workplace you will also need to give some thought to whether it will be more convenient to have several smaller parking facilities or one large one.

4. Costs and funding

The cost of cycle parking can vary greatly depending on the type of facility that is needed. A basic 'Sheffield' stand for two cycles typically costs around £100 to buy and install whereas a shelter for 20 bikes can cost anything up to £5000. The cost may seem initially expensive but it is small when compared to increasing car parking capacity and Cycle Shrewsbury can offer grants towards the cost.

To find out more

Contact Neal Challinor;
neal.challinor@shropshire.gov.uk
 tel 01743 255436 or go to
www.cycleshrewsbury.co.uk

